

NTC Thermistor: TCF Type



Lead Frame for Temperature Sensing/Compensation

■ Features

1. RoHS compliant
2. Body size ϕ 3mm
3. Radial lead resin coated
4. -40 ~ +100°C operating temperature range
5. Wide resistance range
6. Cost effective
7. Agency recognition: UL /cUL



■ Recommended Applications

1. Home appliances (air conditioner, refrigerator, electric fan, electric cooker, washing machine, microwave oven, drinking machine, CTV, radio.)
2. Automotive electronics
3. Computers
4. Digital meter

■ Part Number Code

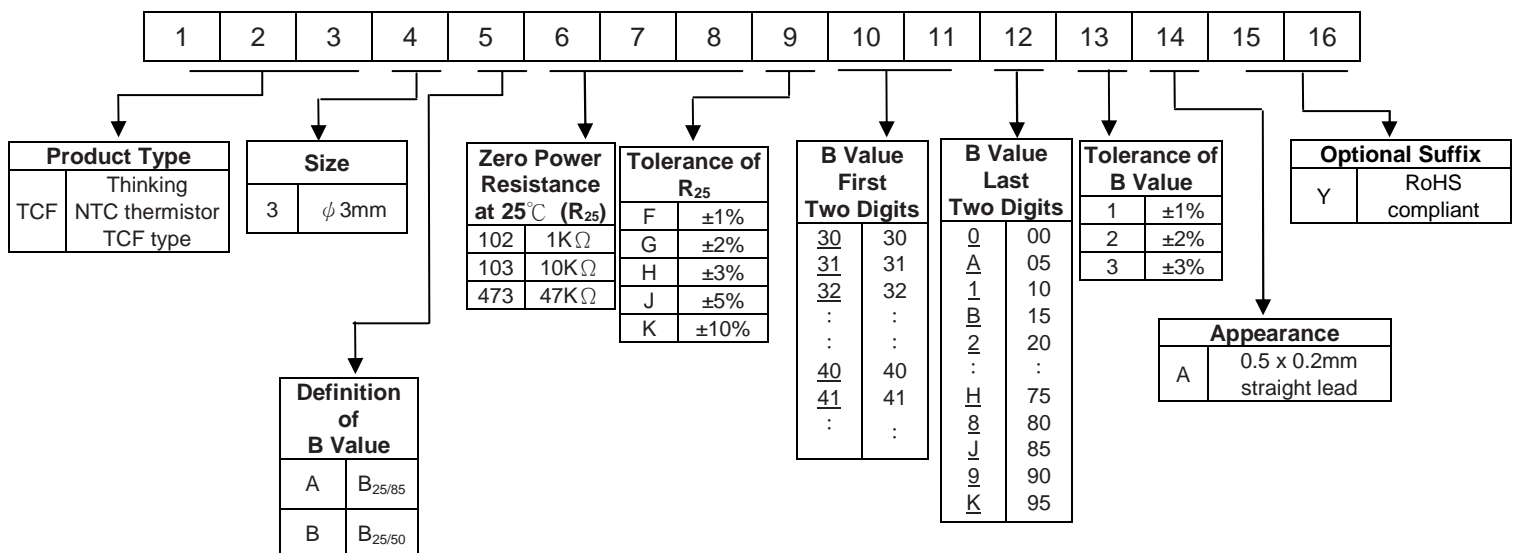

■ Structure and Dimensions

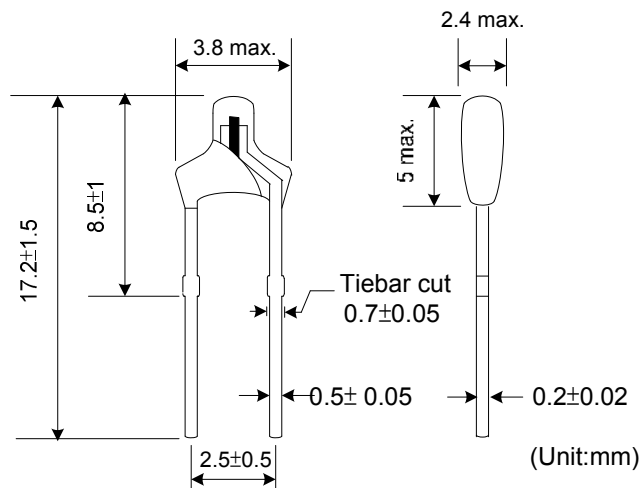

NTC Thermistor: TCF Type



Lead Frame for Temperature Sensing/Compensation

Electrical Characteristics

Part No.	Zero Power Resistance at 25°C	Tolerance of R ₂₅	B _{25/85} Value	Tolerance of B value	Max. Power Rating at 25°C	Dissipation Factor	Thermal Time Constant	Operating Temperature Range	Safety Approvals	
	R ₂₅ (KΩ)	(±%)	(K)	(±%)	P _{max} (mW)	δ(mW/°C)	τ(Sec.)	T _L ~T _U (°C)	UL	cUL
TCF3A202□318*	2	1、2、3、 5、10	3180	1、2、3	150	Approx. 2	Approx. 12	-40~+100	√	
TCF3A502□33C*	5		3325						√	√
TCF3A103□34D*	10		3435						√	√
TCF3A123□347*	12		3470						√	√
TCF3A203□40B*	20		4015						√	√
TCF3A303□409*	30		4090						√	√
TCF3A333□409*	33		4090						√	√
TCF3A473□409*	47		4090						√	√
TCF3A503□406*	50		4060						√	√
TCF3A104□419*	100		4190						√	√

Note 1: □ = Tolerance of R₂₅, * = Tolerance of B value

Note 2: UL/cUL File No E138827

Power Derating Curve

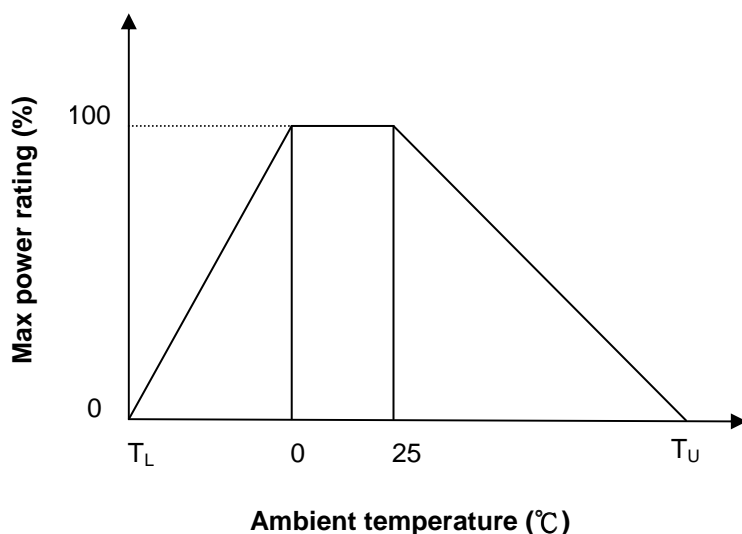

T_U : Maximum operating temperature (°C)

T_L : Minimum operating temperature (°C)

For example : Ambient temperature(T_a)=55°C

Maximum operating temperature(T_U)= 100°C

$P_{Ta} = (T_U - T_a) / (T_U - 25) \times P_{max} = 60\% P_{max}$

NTC Thermistor: TCF Type

Lead Frame for Temperature Sensing/Compensation



■ R-T Characteristic Curves (representative)

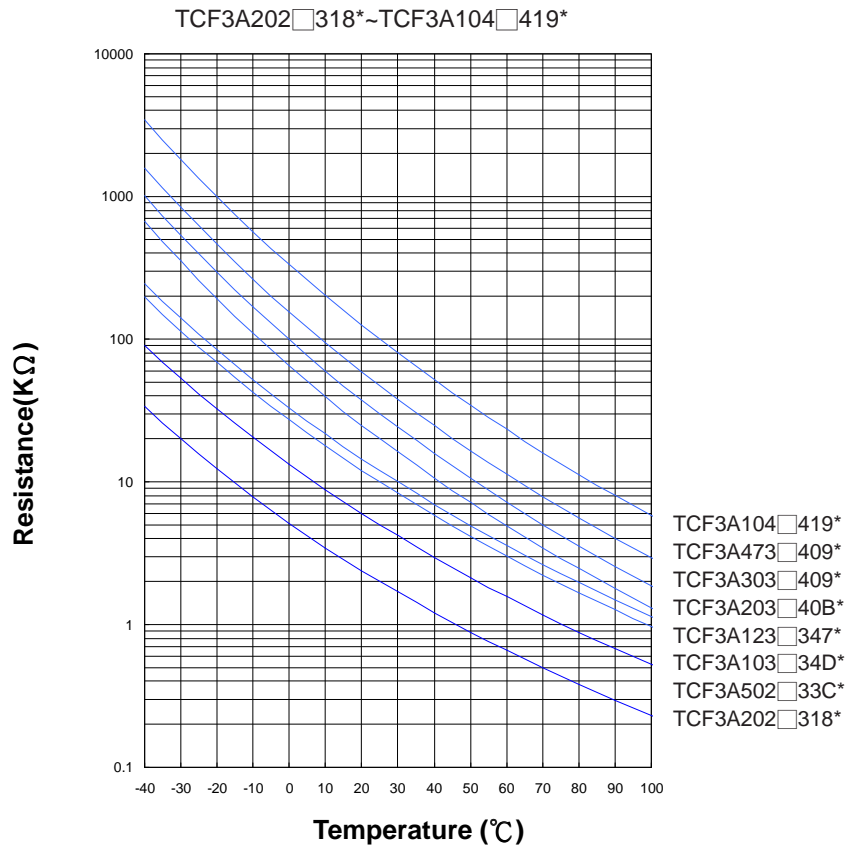

■ Soldering Recommendation

● Wave Soldering Profile

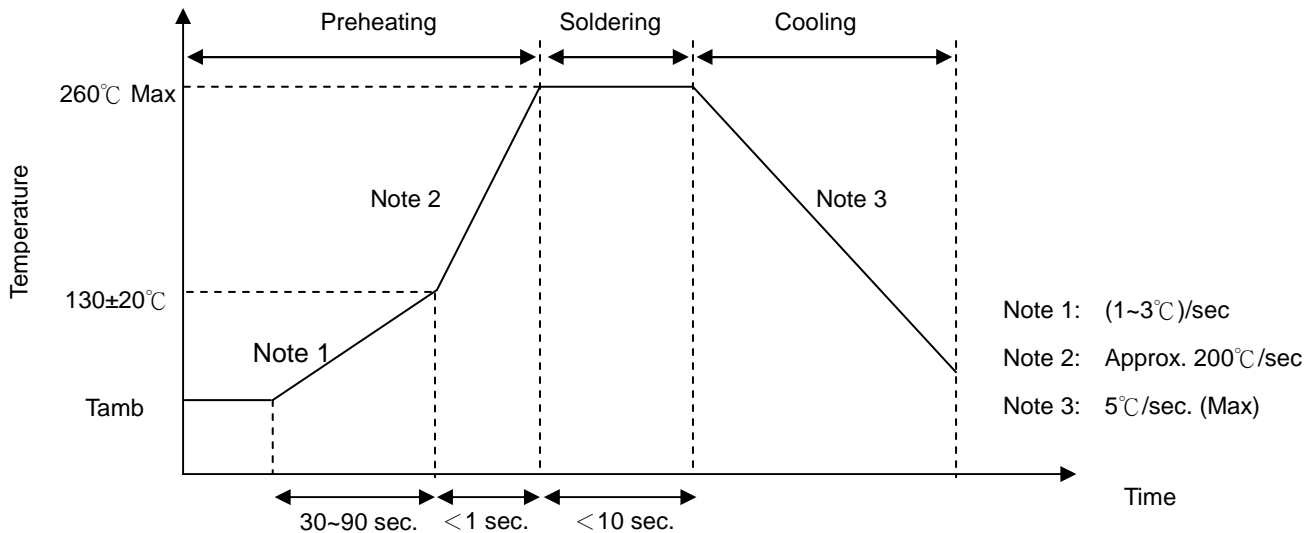

● Recommended Reworking Conditions With Soldering Iron

Item	Conditions
Temperature of Soldering Iron-tip	360°C (max.)
Soldering Time	3 sec (max.)
Distance from Thermistor	2 mm (min.)

NTC Thermistor: TCF Type



Lead Frame for Temperature Sensing/Compensation

■ Reliability

Item	Standard	Test conditions / Methods	Specifications															
Tensile Strength of Terminals	IEC60068-2-21	<p>Gradually applying the force specified and keeping the unit fixed for 10±1 sec</p> <table style="width: 100%; border: none;"> <tr> <td style="text-align: center; width: 50%;">Terminal cross-sectional area (mm²)</td> <td style="text-align: center; width: 50%;">Force (Kg)</td> </tr> <tr> <td style="text-align: center; border-top: 1px solid black;">0.1 < S ≤ 0.2</td> <td style="text-align: center; border-top: 1px solid black;">0.5</td> </tr> </table>	Terminal cross-sectional area (mm ²)	Force (Kg)	0.1 < S ≤ 0.2	0.5	No visible damage											
Terminal cross-sectional area (mm ²)	Force (Kg)																	
0.1 < S ≤ 0.2	0.5																	
Bending Strength of Terminals	IEC60068-2-21	<p>Hold specimen and apply the force specified below to each lead. Bend the specimen to 90°, then return to the original position. Repeat the procedure in the opposite direction.</p> <table style="width: 100%; border: none;"> <tr> <td style="text-align: center; width: 50%;">Terminal cross-sectional area (mm²)</td> <td style="text-align: center; width: 50%;">Force (Kg)</td> </tr> <tr> <td style="text-align: center; border-top: 1px solid black;">0.1 < S ≤ 0.2</td> <td style="text-align: center; border-top: 1px solid black;">0.25</td> </tr> </table>	Terminal cross-sectional area (mm ²)	Force (Kg)	0.1 < S ≤ 0.2	0.25	No visible damage											
Terminal cross-sectional area (mm ²)	Force (Kg)																	
0.1 < S ≤ 0.2	0.25																	
Solderability	IEC60068-2-20	235 ± 5°C , 2 ± 0.5 sec	At least 95% of terminal electrode is covered by new solder															
Resistance to Soldering Heat	IEC60068-2-20	260 ± 5°C , 10 ± 1 sec	No visible damage ΔR ₂₅ /R ₂₅ ≤ 3 %															
High Temperature Storage	IEC60068-2-2	100 ± 5°C , 1000 ± 24 hrs	No visible damage ΔR ₂₅ /R ₂₅ ≤ 5 %															
Damp Heat, Steady State	IEC60068-2-3	40 ± 2°C , 90~95% RH , 1000 ± 24 hrs	No visible damage ΔR ₂₅ /R ₂₅ ≤ 3 %															
Rapid Change of Temperature	IEC60068-2-14	<p>The conditions shown below shall be repeated 5 cycles</p> <table border="1" style="width: 100%; border-collapse: collapse; text-align: center;"> <thead> <tr> <th>Step</th> <th>Temperature (°C)</th> <th>Period (minutes)</th> </tr> </thead> <tbody> <tr> <td>1</td> <td>-40 ± 5</td> <td>30 ± 3</td> </tr> <tr> <td>2</td> <td>Room temperature</td> <td>5 ± 3</td> </tr> <tr> <td>3</td> <td>100 ± 5</td> <td>30 ± 3</td> </tr> <tr> <td>4</td> <td>Room temperature</td> <td>5 ± 3</td> </tr> </tbody> </table>	Step	Temperature (°C)	Period (minutes)	1	-40 ± 5	30 ± 3	2	Room temperature	5 ± 3	3	100 ± 5	30 ± 3	4	Room temperature	5 ± 3	No visible damage ΔR ₂₅ /R ₂₅ ≤ 3 %
Step	Temperature (°C)	Period (minutes)																
1	-40 ± 5	30 ± 3																
2	Room temperature	5 ± 3																
3	100 ± 5	30 ± 3																
4	Room temperature	5 ± 3																
Life Test	IEC 60539-1	25 ± 5°C, Pmax. , 1000 ± 24 hrs	No visible damage ΔR ₂₅ /R ₂₅ ≤ 5 %															
Insulation Test	MIL-STD-202F-Method 302	500 V _{DC} 1 min	No visible damage ≥ 100 MΩ															
Hi-pot Test	MIL-STD-202F-Method 301	1000 V _{AC} 1 min	No visible damage															

NTC Thermistor: TCF Type



Lead Frame for Temperature Sensing/Compensation

■ Packaging

- Bulk Packing : 1000 pcs/ bag

■ Storage Conditions of Products

- Storage Conditions :
 1. Storage Temperature : $-10^{\circ}\text{C} \sim +40^{\circ}\text{C}$
 2. Relative Humidity : $\leq 75\% \text{RH}$
 3. Keep away from corrosive atmosphere and sunlight.
- Period of Storage : 1 year